



PROFESSIONAL AUDIO SYSTEM

SM1



OPERATING MANUAL

Ver. SM1-EN-1.1

**LSS Advanced Speaker Systems**

Via On. Longo 53-89024 Polistena (RC) ITALY Tel (39) 966 9321299 – Fax (39) 966 933007 Email: info@lss.it - Internet: www.lss.it

## **NOTICE:**

LSS products are manufactured for use according to proper procedures by a qualified operator and only for the purposes described in this manual. The following conventions are used to indicate and classify precautions in this manual. Always heed the information provided with them. Failure to heed precautions can result in injury to people or damage to property.

## **© LSS, 2016**

All rights reserved. No part of this publication may be reproduced, stored in a retrieval system, or transmitted, in any form, or by any means, mechanical, electronic, photocopying, recording, or otherwise, without the prior written permission of LSS.

No patent liability is assumed with respect to the use of the information contained herein. Moreover, because LSS is constantly striving to improve its high-quality products, the information contained in this manual is subject to change without notice. Every precaution has been taken in the preparation of this manual. Nevertheless, LSS assumes no responsibility for errors or omissions. Neither is any liability assumed for damages resulting from the use of the information contained in this publication.

---

## SUMMARY

INTRODUCTION .....	4
SAFETY AND WARNING.....	5
APPLICATION.....	6
PHYSICAL DESCRIPTION.....	6
TECHNICAL SPECIFICATIONS .....	7
INSTALLATION AND WIRING .....	8
WEEE DIRECTIVE .....	11
TROUBLESHOOTING .....	12
DIMENSIONS.....	13
NOTES .....	14

## INTRODUCTION

Congratulation on the purchase of your new LSS loudspeaker. Quality innovation and versatility, this is a summary of the new system developed by LSS for professional sound users. LSS produces professional audio products – the result of exceptional engineering and meticulous craftsmanship. This manual is intended for use with LSS loudspeaker. This includes: safety precautions; installation, set-up and operating instruction. Please read this manual plus any accompanying manual and follow all relevant precautions and instructions. This should allow you to obtain the maximum performance from your new loudspeaker. Where there are conflicts or overlaps, the information in any accompanying manual supersedes the information in this manual.

## SAFETY AND WARNING

### IMPORTANT! SAFETY WARNING!

In the interest of their own and others' safety and to prevent voiding the warranty, we recommend a careful reading of this section before using the product.

- This product was designed and manufactured to be used as a speaker system in the context of a typical sound reinforcement system.

The use for any purpose other than these is not provided by the manufacturer and is therefore under the direct responsibility of the user / installer.

- This device complies with class I (must be connected to the outlet with a protective earthing connection).



#### WARNING

RISK OF ELECTRIC SHOCK  
DO NOT OPEN

TO REDUCE THE RISK OF ELECTRIC SHOCK  
DO NOT REMOVE COVER (OR BACK)  
NO USER SERVICEABLE PARTS INSIDE  
REFER SERVICING TO QUALIFIED SERVICE PERSONNEL  
TO REDUCE THE RISK OF FIRE OR ELECTRIC SHOCK  
DO NOT EXPOSE THIS EQUIPMENT TO RAIN OR MOISTURE

### TO AVOID THE RISK OF FIRE AND / OR ELECTRIC SHOCK\*:

- Do not expose this system to rain or moisture. Do not expose the apparatus to dripping or splashing water. Do not place objects filled with liquids, such as drinks, on the apparatus.

- Before connecting the system, be sure the mains voltage corresponds to that stated on the product.

- Connect this appliance to a power outlet with earth contact, according to national security force, via a power cable of adequate section ends with a plug or connector that meets the applicable safety regulations.

- The unit is connected to the network even when the power switch is in position '0' (OFF). Before any maintenance, disconnect the power cable from the outlet.

\*Risk of electric shock only for self-powered system.

### IMPORTANT! SAFETY PRECAUTIONS!

Read This First.

Read and heed all warnings and safety instructions in this Manual before using the product.

Failure to follow all precautions can result in equipment damage and / or personal injury.

1. Read these instructions.
2. Keep these instructions
3. Heed all warnings and follow all instructions.
4. Use only attachments/accessories specified by the manufacturer.
5. Use only with the cart, stand, tripod, bracket, or table specified by the manufacturer, or sold with the apparatus. When a cart is used, use caution when moving the cart/apparatus combination to avoid injury from tip-over.
6. Refer all servicing to qualified service personnel. Servicing is required when the apparatus has been damaged in any way, such as power-supply cord or plug is damaged, liquid has been spilled or objects have fallen into the apparatus, the apparatus has been exposed to rain or moisture, does not operate normally, or has been dropped.
7. LSS loudspeakers can produce sound levels capable of causing permanent hearing damage from prolonged exposure. The higher the sound level, the less exposure needed to cause such damage

CAUTION: This product is energized as long as it is connected to the AC.

CAUTION: Allow at least six inches of free space all around the amplifier for sufficient ventilation.

## APPLICATION

LSS's SM1 is a near-field sound monitoring system designed to support the widest range of studio monitor applications.

Ultra flat frequency response and physical phase alignment assure a precise reference for pro audio applications. SM1 system comprises a 160 mm (6") Ferrite LF, 1.5" voice coil Kapton former, Progressive spider, Rubber surround with DAR technology, a 28 mm (1.1") silk treated soft dome Neodymium HF, 1.1" voice coil aluminium former and flat aluminium wire with additional damping treatment, cooling radiator to reduce power compression and damped rear chamber.

LSS's advanced crossover includes professional protection of HF. Powering mode is full range passive with internal crossover filter network, on request Bi-Wiring passive mode.

## PHYSICAL DESCRIPTION

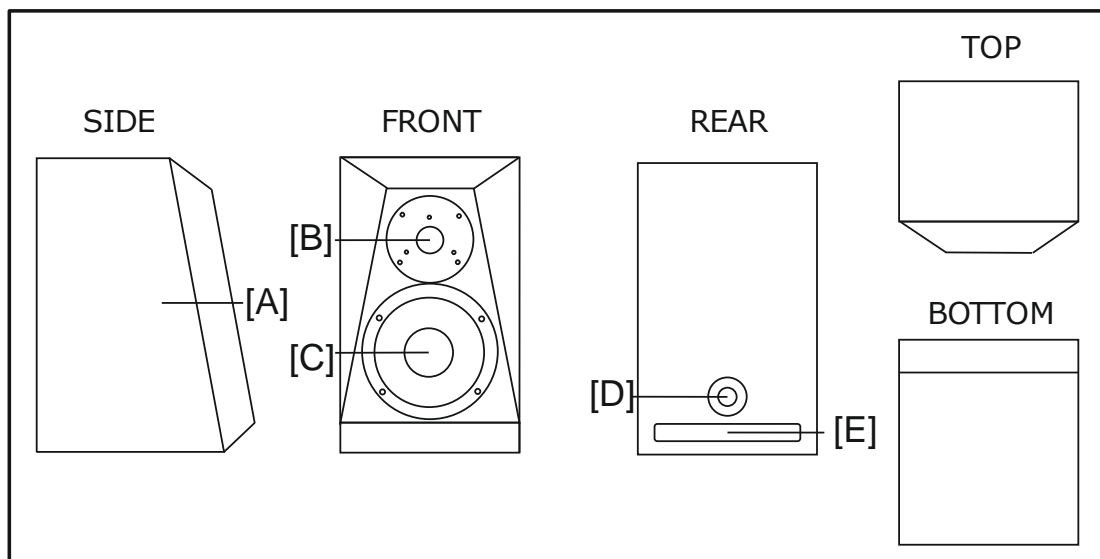

[A] Enclosure Cabinet  
[B] HF Driver  
[C] Woofer

[D] Speakon Connector  
[E] Reflex

Materials and construction meet the highest professional standards to ensure maximum reliability.

## TECHNICAL SPECIFICATIONS

<b>PHYSICAL</b>	<b>Dimensions mm (±1 mm) [Inches]</b>	Height 385 [15.19"]
		Width 230 [9.05"]
		Depth 286 [11.25"]
	<b>Weight Kilograms</b>	Net Weight 8.7
Shipping Weight 10		
<b>SYSTEM PERFORMANCE</b>	<b>Frequency Response</b>	±5 dB 50 Hz ~ 20 KHz
		-10 dB 45 Hz
	<b>Sensitivity (1 Watt @ 1 m)</b>	Full Range Passive 90 dB
	<b>Max SPL Calculated Power AES [PEAK]</b>	112 dB [118 dB]
	<b>Nominal Input Impedance (Ω)</b>	Full Range Passive 8 Ω
		LF 8 Ω
		HF 8 Ω
	<b>Power Handling (Watt cont. AES)</b>	Full Range Passive 150 W
<b>Peak Power</b>	600 W	
<b>Nominal Dispersion (@ -6 dB)</b>	Horizontal 90°	
	Vertical 90°	
<b>MECHANICAL</b>	<b>Enclosure material</b>	MDF of 20 mm [0.78 inches]
	<b>Finish</b>	Natural Wood Texture
	<b>Connectors</b>	One Neutrik Speakon NL4
	<b>Optional Accessories</b>	Flight case

## INSTALLATION AND WIRING

SM1 is a monitor speaker and should be placed in a studio.

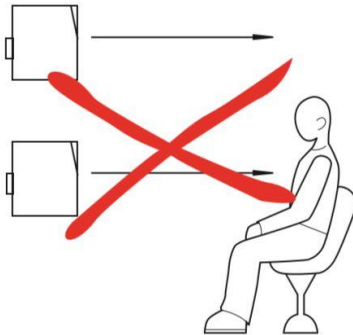

If you use the monitors on a desktop, they usually will need to be angled. Please note that vibrating parts of nearby objects can mask the sound, so make sure that there are no obstacles in the way from the monitor to your ears. You should be able to see the speakers completely.

Do not place the speakers directly in front of a wall because the bass reflex tubes are located on the back of the speaker.

The SM1 have been designed for a vertical setup. The speakers must be positioned on a solid surface or a stand.

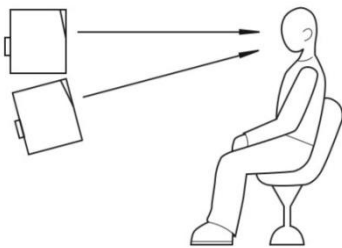

The Tweeter should be positioned approximately at the height of your ears. If the speaker does not point right in your direction, you might lose sound information.

In case you need to position the speaker in a significant lower or higher position, the monitor should be angled accordingly.

If the loudspeaker is going to be used for stereo applications, the optimum listening position should be at the top of an imaginary equilateral triangle with the two loudspeakers should be placed at the other two points of this triangle. The loudspeakers should be aligned with the listener's position.

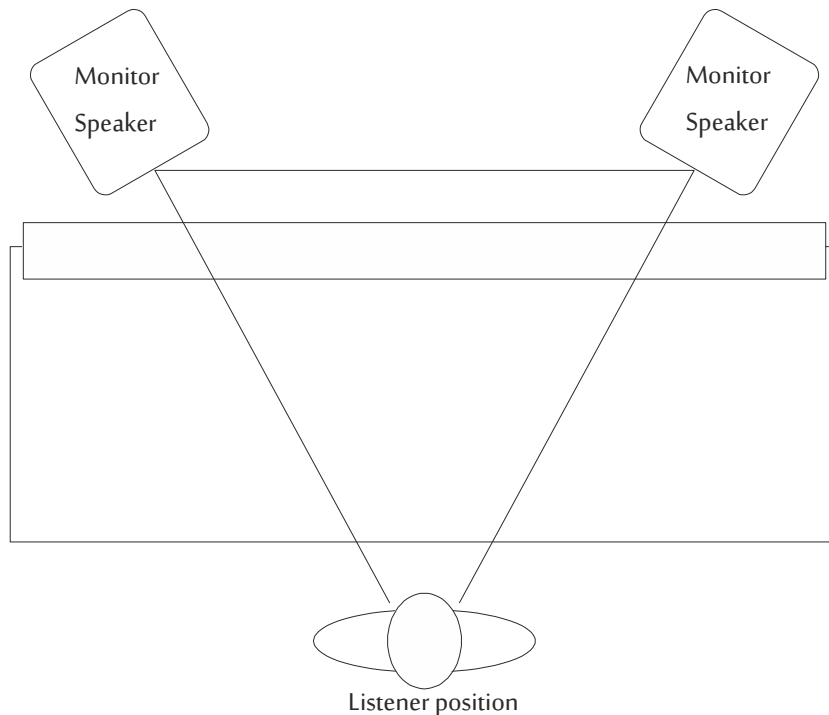



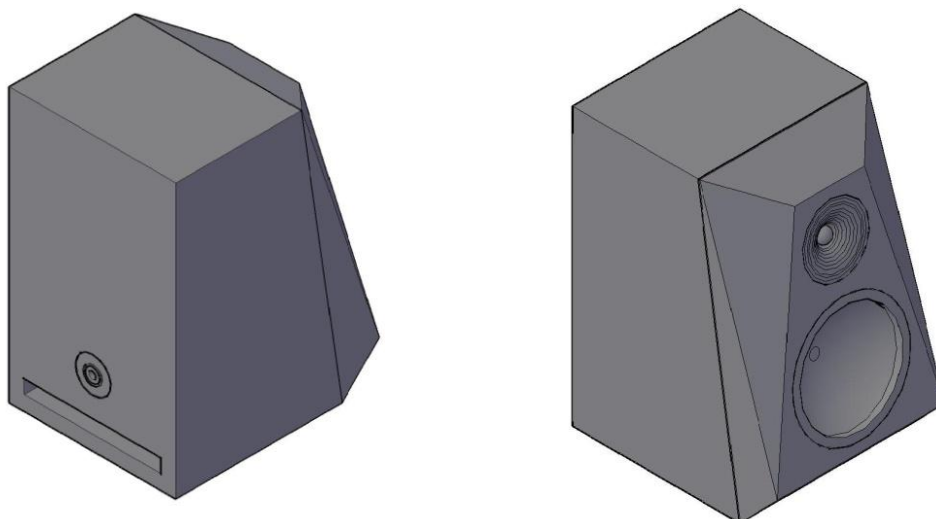

Choose a safe mounting location, so as to prevent the cables can be stepped on or create tripping hazards.

Before making connections between mixer and speakers, make sure the mixer volume is turned down.

In the rear of the speaker there is a NL4 Speakon connector to use as input signal. In the SM1 both the LF and HF drivers are connected to pins 1+/1- of the NL4 connector.

Channel 2 has been linked from In to the out.

Recommended configuration using multiple studio monitors is represented below:

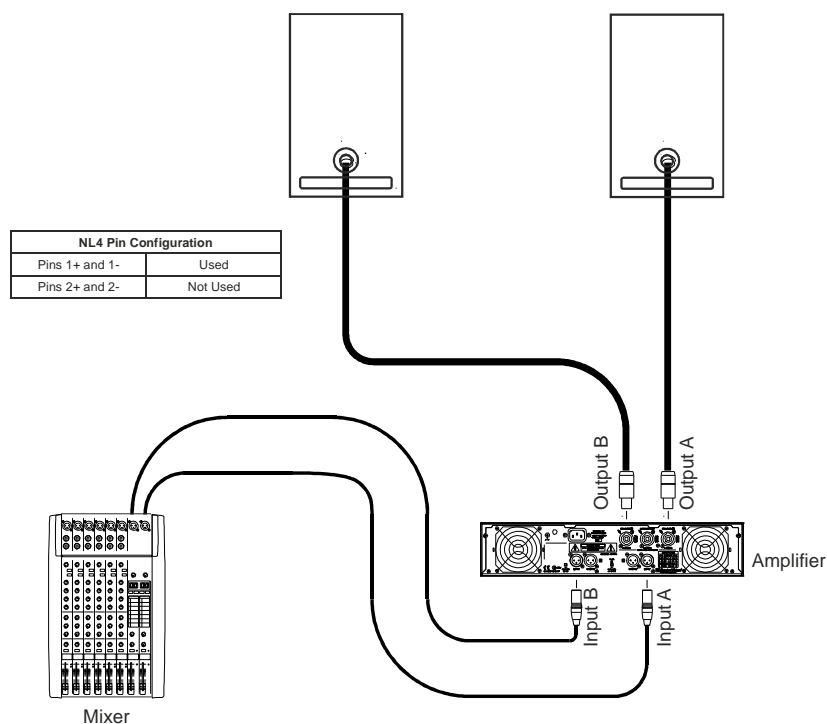

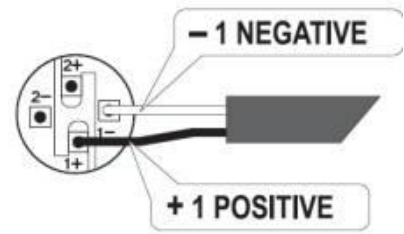
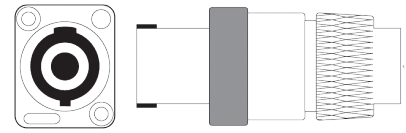
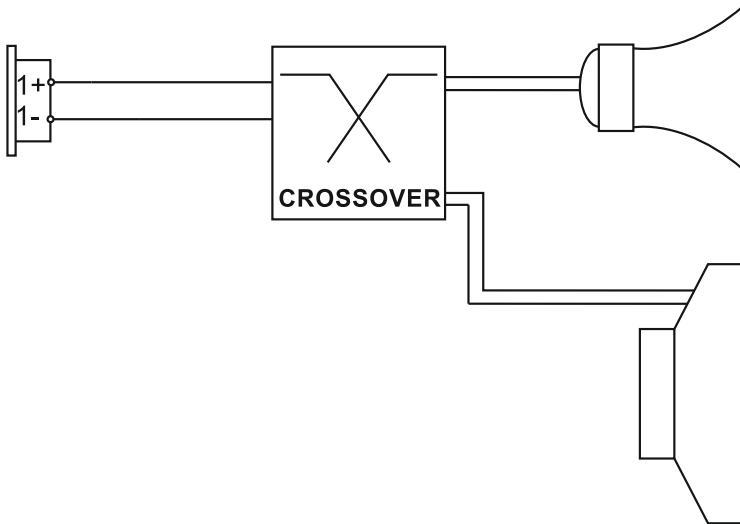

## WEEE DIRECTIVE

### WEEE Directive

#### Warning!

The product is marked with this symbol which indicates not to discard electrical and electronic equipment via the normal procedure for disposal of household waste. For these products there is a diverse collection system in accordance with legislation that requires proper treatment, recovery and recycling of used products. For more information please contact the appropriate local authority.

The black bar underneath indicates that the product was placed on the market after 13 August 2005.

### INFORMATION FOR PROPER DISPOSAL

#### For home users

##### In the European Union

Warning: To dispose of this equipment, do not use the ordinary dust bin!

The electrical and electronic equipment must be treated separately and in accordance with legislation that requires proper treatment, recovery and recycling of used products. Following the implementation by member states, private households within the EU can give free electrical and electronic equipment to designated collection facilities \*.

In some countries (\*), your local retailer may withdraw the old product for free if you purchase a new one of similar type.

\* For more information please contact the appropriate local authority.

**In countries outside the EU:** please contact your local authorities and ask for the correct method of disposal.

**In Switzerland:** Used electrical or electronic equipment can be returned free of charge to the dealer, even if you do not purchase a new product.

Further collection facilities are listed on the homepage or [www.swico.ch](http://www.swico.ch).  
[www.sens.ch](http://www.sens.ch).

#### For professional users

##### In the European Union

Warning: If the product is used for business purposes, the following steps to delete it:

contact your LSS dealer for information about the product recall.

Might be charged for the costs of collection and recycling. Small products (and amounts) might be taken back by your local collection facilities.

**In Spain:** contact the established collection system or the local authority for collection of used products.

**In countries outside the EU:** please contact your local authorities and ask for the correct method of disposal.



## TROUBLESHOOTING

Problem	Possible cause (s)	Action
1. No Sound	Amplifier	Connect a known working test speaker to the amplifier outputs. If there is no sound, check that all the electronics are on, the signal routing is correct, the source is active, the volume is turned up, and so on. Correct/repair/replace as necessary. If there is sound, the problem is in the wiring.
	Wiring	Verify that you have connected the correct wire pairs to the amplifier. Play something at low level through the amplifier (for example, from a CD player or tuner). Connect the test speaker in parallel with the malfunctioning line. If the sound level has gone or is very weak, the line has a short in it (possibly a severe scrape, pinch, or staple puncture). If the sound level is normal, the wire is open (possibly a cut wire or a missed connection). Using the test speaker, move down the line and test each connection/junction until you find the problem and correct it. Observe proper polarity.
2. Poor Low Frequency Response	Speakers wired out-of-polarity	When two speakers are connected out of polarity, the low frequencies will cancel each other acoustically. Carefully observe the wire markings or tracers on your speaker wires. Verify that the amplifier (+) terminal is connected to pin 1+ of the NL4 connector and the amplifier (-) terminal is connected to pin 1- of the NL4 connector.
3. Intermittent output such as crackling or distortion	Faulty Connection	Check all connections at amplifier and speakers to ensure they are all clean and tight. If the problem persists, it may be in the amplifier or wiring. See Problem 1 above.
4. Constant noise such as buzzing, hissing, humming	Defective amplifier or other electronic Devices	If the noise is present but no program material is playing, the likely cause is the signal chain in the electronics. Evaluate each component as necessary to isolate the problem.
	Poor system grounding or ground loop	Check and correct the system grounding, as required.
If these suggestions do not solve your problem, contact your nearest LSS dealer or LSS distributor.		

## DIMENSIONS

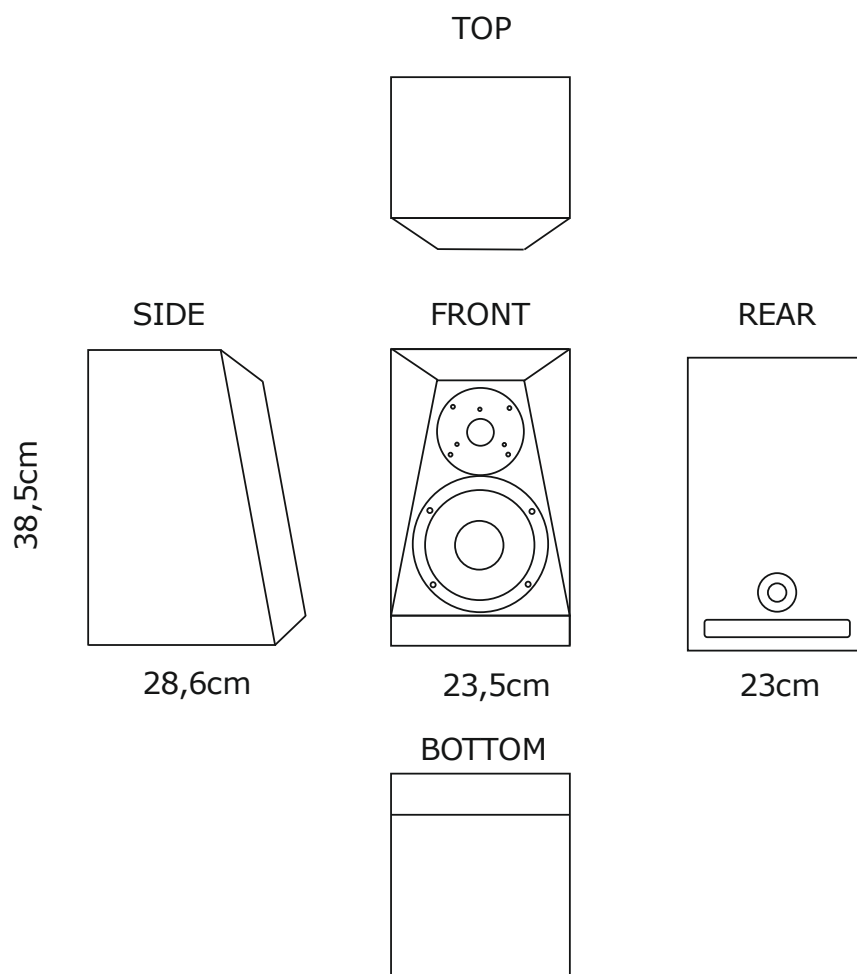

**NOTES**



**CONTACT INFORMATION:**

**LSS Advanced Speaker Systems**

Via On. Longo 53  
89024 Polistena (RC) ITALY  
Tel (39) 966 9321299 – Fax (39) 966 933007  
Email: [info@lss.it](mailto:info@lss.it) - Internet: [www.lss.it](http://www.lss.it)